

HYD. K.O. PLATE

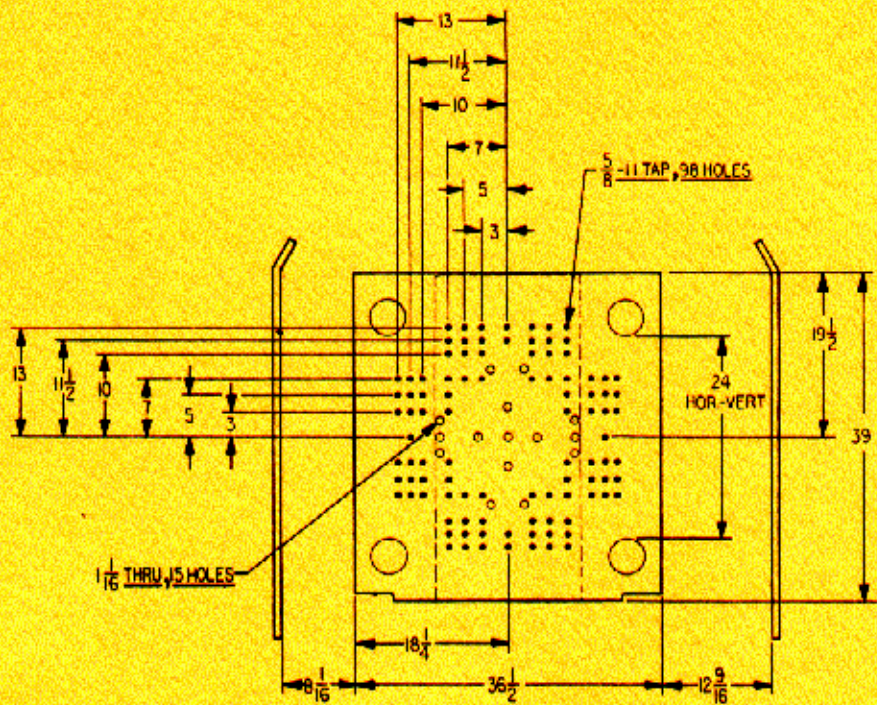

MOVABLE PLATEN

300-RS-14/20/30/35/60F

Van Dorn's fluid drive, or F-Series, toggle clamp machines feature hydraulically driven screws that generate high-quality homogeneous melts at high rates. Stable screw speeds and precise, infinitely variable back pressure control are features contributing to outstanding molding output.

Add faster set-ups, improved molding speeds and minimal maintenance and you have the injection molding capability molders identify with the name, Van Dorn.

STANDARD FEATURES

- Large part removal clearance
- Purge guard with interlock
- Swing away material hopper
- Integral-base drip pan
- Full-floating hardened toggle pins
- Automatic oil lubrication.

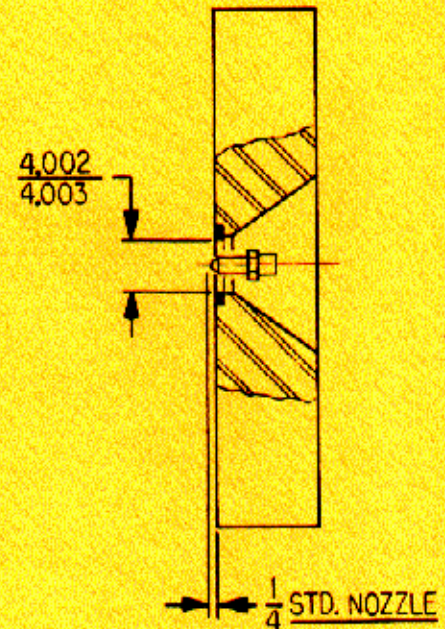

STATIONARY PLATEN

VAN DORN®

Committed to the future of plastics

VAN DORN PLASTIC MACHINERY CO., / A Division of Van Dorn Company

11782 Alameda Dr. • Strongsville, Ohio 44136 • Write: P.O. Box 8848 • Strongsville, Ohio 44136 • Telephone: (216) 238-8960