

# LARGE TONNAGE

Van Dorn Caliber

DemagPlastics Group  
VAN DORN Caliber 2200-12300

1100 - 4400

**Demag**Plastics Group  
VAN DORN

VAN DORN CALIBER

# A NEW REALITY

## Two Platens

**If you operate in the most competitive markets in plastics – automotive, housewares, appliances – the concept “productivity per square foot” means a lot to you. The Caliber Series design is driven by this concept.**

With the consolidation of components, the ever-increasing size of molds, and advancements in materials and machine technology, the molding of large parts is one of the most dynamic, fastest growing segments in the plastics processing industry. If you are a molder who uses machines weighing in at more than 1000 tons of clamp force, opportunities abound – so do many challenges. In the arena of large machines, two-platen technology is an answer.

When you’re looking at two-platen machines, you have to ask which manufacturer is using this new technology in a smart way. Van Dorn Demag has mastered two-platen technology to your advantage with the Caliber Series. We assembled a global engineering team to design a solution that combines the best of Europe’s experience in two-platens with our expertise in large part manufacturing in the U.S. The result is a design that delivers proven world-class performance. Van Dorn Demag’s manufacturing excellence works on your behalf as well. We have a history of building highly productive, large tonnage machines.

Our team of highly trained, experienced assemblers are dedicated to large machines only. We are ISO 9001 and QS9000 TE-Supplement certified. After 20+ years of building machines 1000 tons and over, we can offer advice on what it takes to rig and ship a machine through your door and onto your floor. With our Planned Machine Subassembly program, we produce major subassemblies in advance of receiving a purchase order to reduce lead time on large machines. With pre-engineered options, we make sure you get fast delivery and the machine configuration you need. Van Dorn Demag Corporation draws on a rich 50-year history and our association with Mannesmann Plastics Machinery, the largest supplier of injection molding machines in the world. While we offer a broad product line, we are strictly focused on injection molding. We know your business because it’s our business – our only business.



Van Dorn

Whether you're molding casings for digital flat panel technology or a challenging, deep-draw application, the Caliber's generous specifications give you maximum flexibility in substantially reduced floor space.

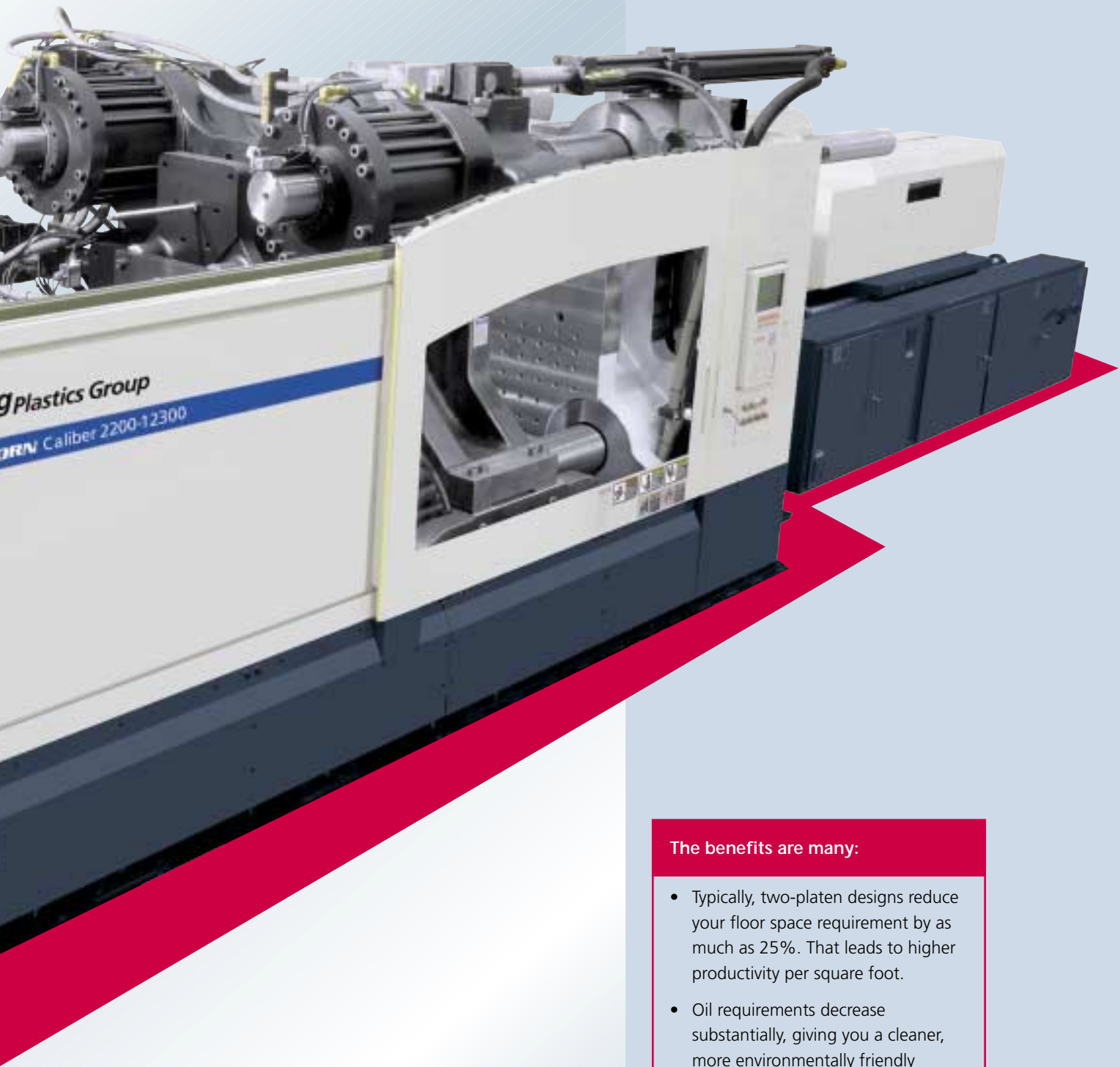

**The benefits are many:**

- Typically, two-platen designs reduce your floor space requirement by as much as 25%. That leads to higher productivity per square foot.
- Oil requirements decrease substantially, giving you a cleaner, more environmentally friendly machine.
- Generous specifications allow you to purchase more molding capability in a smaller size machine.

# Dorn Caliber

# CLAMP UNIT

Innovation at its Smartest

The Caliber Series has a simple but elegant solution to the two-platen arrangement. Even with specifications that meet or beat the competition, the Caliber reduces footprint by at least 25% over hydraulic designs but never sacrifices clamp stability or power. Unlike some complicated two-platen designs, we've reduced the locking and guidance system's complexity, minimized the number of parts, and provided clear accessibility so that clamp maintenance is simple.

The Caliber starts out in the mold open position with its four tie bars retracted. Now you've got unobstructed access to mount your mold, auxiliaries, and any automation required for part removal. When you're ready to close the clamp, two advance cylinders connected to the movable and stationary platens pull the moving platen and four retracted tie bars toward the stationary platen until the mold is closed. The tie bars are machined with several evenly spaced notches that are faster, easier and more secure to locate and lock than thin threads or grooves.

The notches are designed to minimize stresses to ensure their integrity under load. Once the mold is closed, the caliper locking system is engaged, and the four tonnage cylinders complete the mold close sequence by building tonnage between the platens.



Using I-beam columns surfaced with hardened steel pads, the Caliber Series offers superior stability across the entire opening stroke. You won't find a more robust support system for platens and molds than our yoke design.

Clamp Tonnage Cylinder

Tie Bar Rear Bearing

Ejector Assembly

Moving Platen

Platen Guide Rod

Support Pads

Platen Guide Yoke

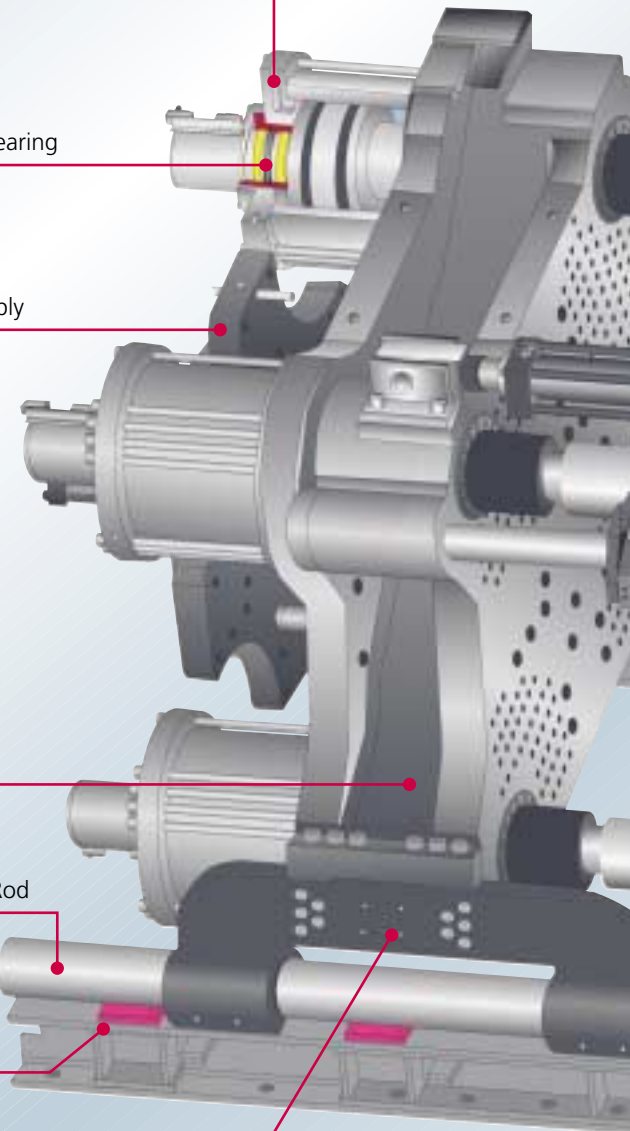

# Dorn Caliber

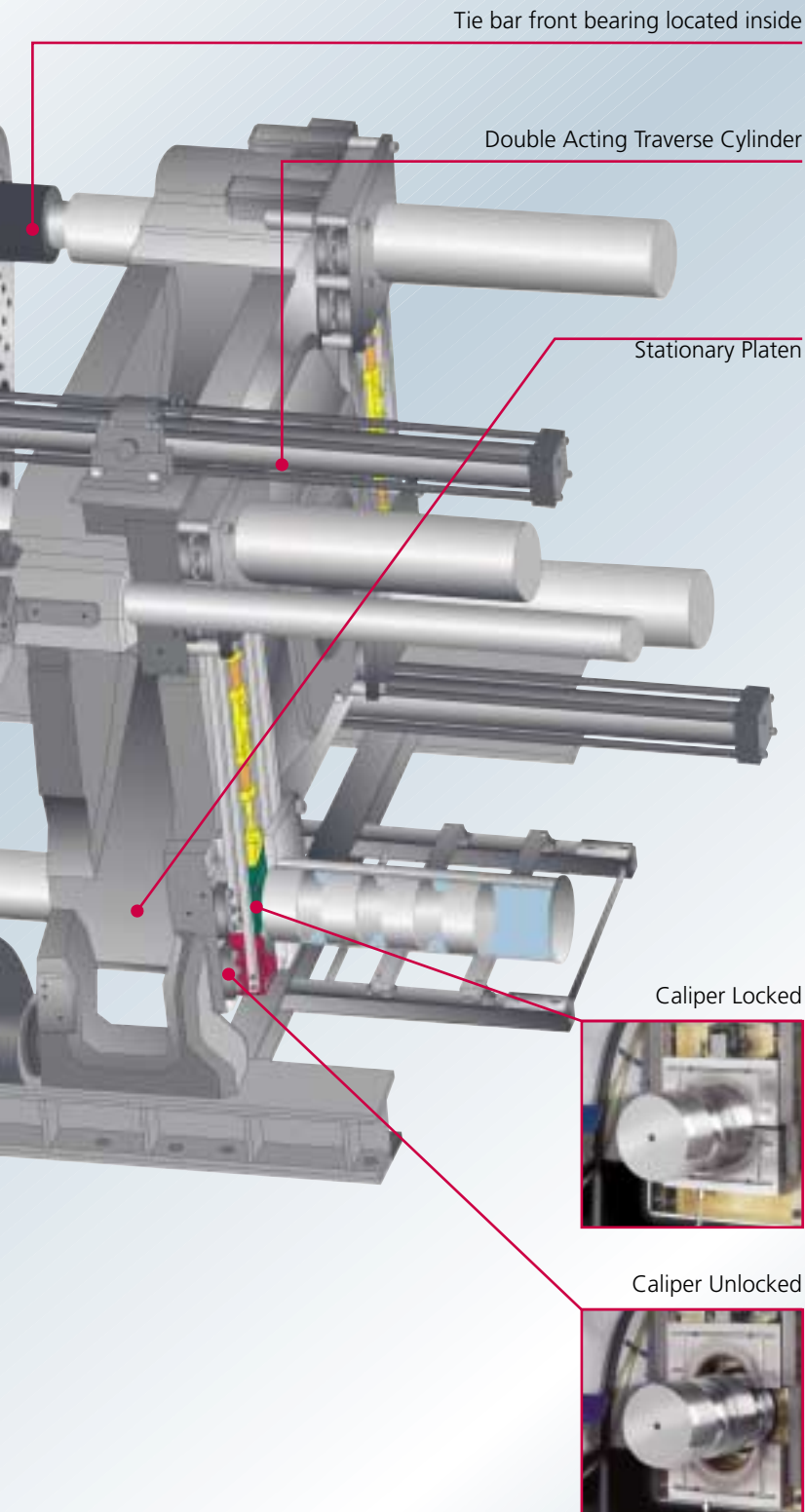

When it's time to open the mold, the Pathfinder® control quickly moves cylinders into action to release the tie bars and move the platen nearly simultaneously for an efficient mold break. To adjust mold height for a new mold, you simply push the mold height setup key on the Pathfinder control and watch the machine and control do the rest. Clamp tonnage is easily adjustable from the operator panel.

The Caliber Series exceeds the standards for platen parallelism set by conventional hydraulic machines. An immense yoke featuring 270° containment rigidly supports the platen and the largest molds. The yoke travels on bushings that encircle fixed guide rods to minimize resistance, tipping or twisting. The bushings are constructed of a bronze composite material for longevity, friction resistance and consistent load response.

Strength of the platen is derived from an advanced design and thickness so that deflection is not a concern. Using finite element analysis (FEA), we engineered load-balanced platens to direct force from the corners of the platen to the center of the mold. SPI mold-mounting and knockout patterns are standard.

The simplicity of our wear-resistant solution makes it cost-effective in terms of time required for standard maintenance and number of replacement parts, particularly when compared to other maintenance-intensive solutions.

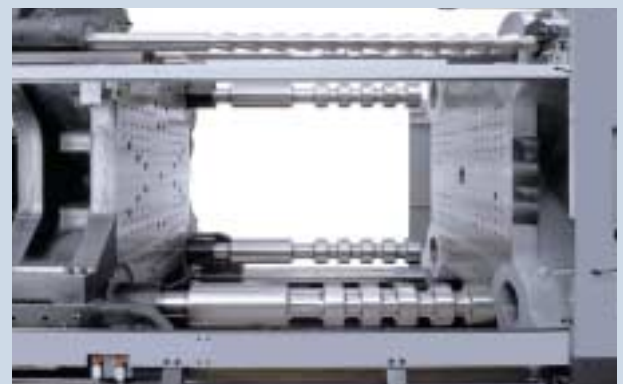

Wide open spaces are characteristic of most two-platen designs. Not only are specifications generous but hanging molds and auxiliaries is facilitated.

The Pathfinder Control's patented Digital Feed Forward technology predicts clamp position with unprecedented exactness. It automatically determines the location at which it needs to slow the clamp within 0.01 inches to safely reach the stop position. This enhances repeatability while maximizing cycle time. Low-pressure mold close and slow mold breakaway protect your tooling investment.

A hydraulic ejector system features walk-up accessibility from the rear of the Caliber Series to connect knockout rods. Its recessed position means you will never have to give up daylight or mold height for ejector stroke. The ejector system is designed to meet your need for a rigid, well-guided ejector with a very long stroke. Eject-on-the-fly, center eject, eject forward hold, positive stops and multiple eject sequences are standard.

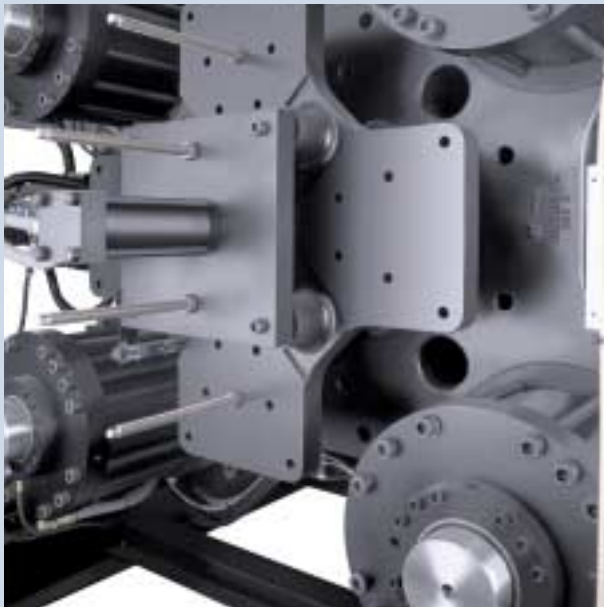

Always there when you need it, you will never have to remove this ejector system to gain daylight or stroke.



Service tracks neatly contain hydraulics, as well as electrical wiring, water hoses, and connections.

One of our customers originally asked us to quote a 1500-ton machine to run his automotive trim mold. When we took a look at his application, it was clear that due to the generous tie-bar spacing of the Caliber Series, he only needed to pay for an 1100 Caliber to get the job done.

# HYDRAULIC SYSTEM

## The Muscle

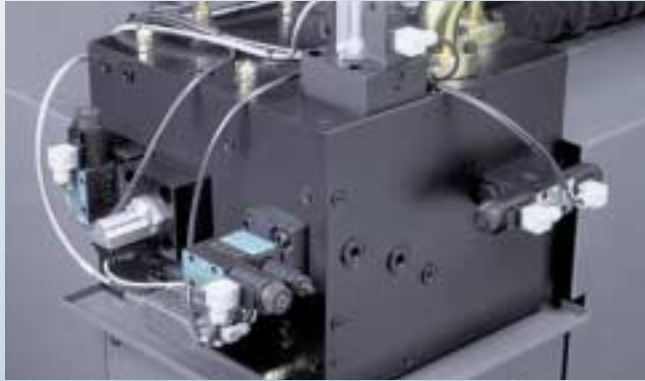

Injection manifold



Clamp manifold



We've made sure the hydraulics are accessible for ease of maintenance. Of course, our Three Year, No Leak Guarantee applies to the Caliber Series.



Let's get to the point. The Caliber uses one-third as much hydraulic oil for motion control than hydraulic machines of the past. That's less oil to buy, clean and dispose of. Safety, housekeeping, and environmental experts will be satisfied.

The Caliber Series needs about two-thirds the horsepower required by machines in the past. For instance, the 1760 Caliber uses a 175 horsepower motor where its predecessor used a 250 horsepower motor. Need we say more about energy efficiency? What's left of the hydraulics is simplified with minimal components and a reduced number of leak points. We borrowed heavily from our No Leak initiatives, using SAE O-ring fittings, strict tolerance manifolds, tough flatness specifications, improved tube and hose installation, and other advancements.

Muscular, fixed-volume pumps are combined with load-sensing circuits for precise control of hydraulic flow. The pumps are staged for maximum energy efficiency. Motors and pumps are covered to reduce noise levels. Cartridge, proportional directional control, and proportional pressure control valves work with the Pathfinder control to provide fast speeds and smooth motion, minimizing pressure drops. Proportional directional control valves are used for repeatable shot control and precise clamp control. Proportional pressure control valves are dedicated to obtaining and maintaining injection and clamp pressure. The injection and clamp manifolds are shock-mounted to prevent pump vibration from being transferred to the machine base.

### The hydraulic system also includes:

- Closed-loop oil temperature control with continual flow through the accessible heat exchanger for steady state cooling
- Full-time oil filtration system with 3-micron filter
- Visible and audible filtration alarms that signal the control system when oil filter is bypassed
- Selectable oil preheat sequence
- High oil-temperature and low oil-level visible and audible alarms

# INJECTION UNIT

## More Dependable; Highly Capable

We have always offered very consistent injection units. Our latest designs build on our reputation for consistency by improving two more performance parameters: increased injection capability and long-term dependability. We want you to obtain precise, repeatable injection cycles no matter how many gate valves you have, how thin the part, how tough the material or how long you own the machine.

Each Caliber is available with a choice of three injection units. Each injection unit is available with a choice of two screw and barrel combinations. Shot sizes range from 104 to 750 ounces. For smaller shot sizes (104 to 140 ounces), the injection unit is our new in-line design. Above 140 ounces, the design is a twin-cylinder version suited to larger shot sizes.

The twin-cylinder injection unit incorporates an advanced carriage guidance system for robust support and precise nozzle alignment, enhanced by a solid barrel support attached to the stationary platen. The high-torque hydraulic screw drive motor is protected by a housing that rides on linear rail supports, providing smooth, low-friction travel for improved wear performance.

Twin pull-in cylinders have the muscular strength required to inject large shot sizes and the durability required for the long haul – a design achievement your maintenance department will appreciate. Of course, the design applies the leak-free technology we developed for our Three Year, No Leak Guarantee.



**The twin-cylinder injection unit is noted for its short profile which contributes to an overall reduction in footprint.**

**A variety of screw and barrel choices are available for the in-line injection unit. Ask us if you need high-pressure or high-speed configurations.**

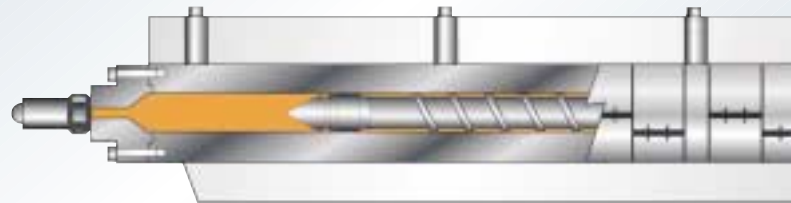

### Characteristics shared by the injection units include:

- Standard injection pressure of 23,000 psi with a second choice for smaller shot sizes or 30,000 psi high-pressure injection
- Screws with 20/1 L/D and 3:1 compression ratio for a high-quality melt
- Wide selection of special screws and barrels to match processing requirements such as 25/1 L/D for improved recovery rates, 2:1 compression ratios or mixing screws
- Easy acceptance of electric screw drive for overlapping cycles and reduction in overall cycle time



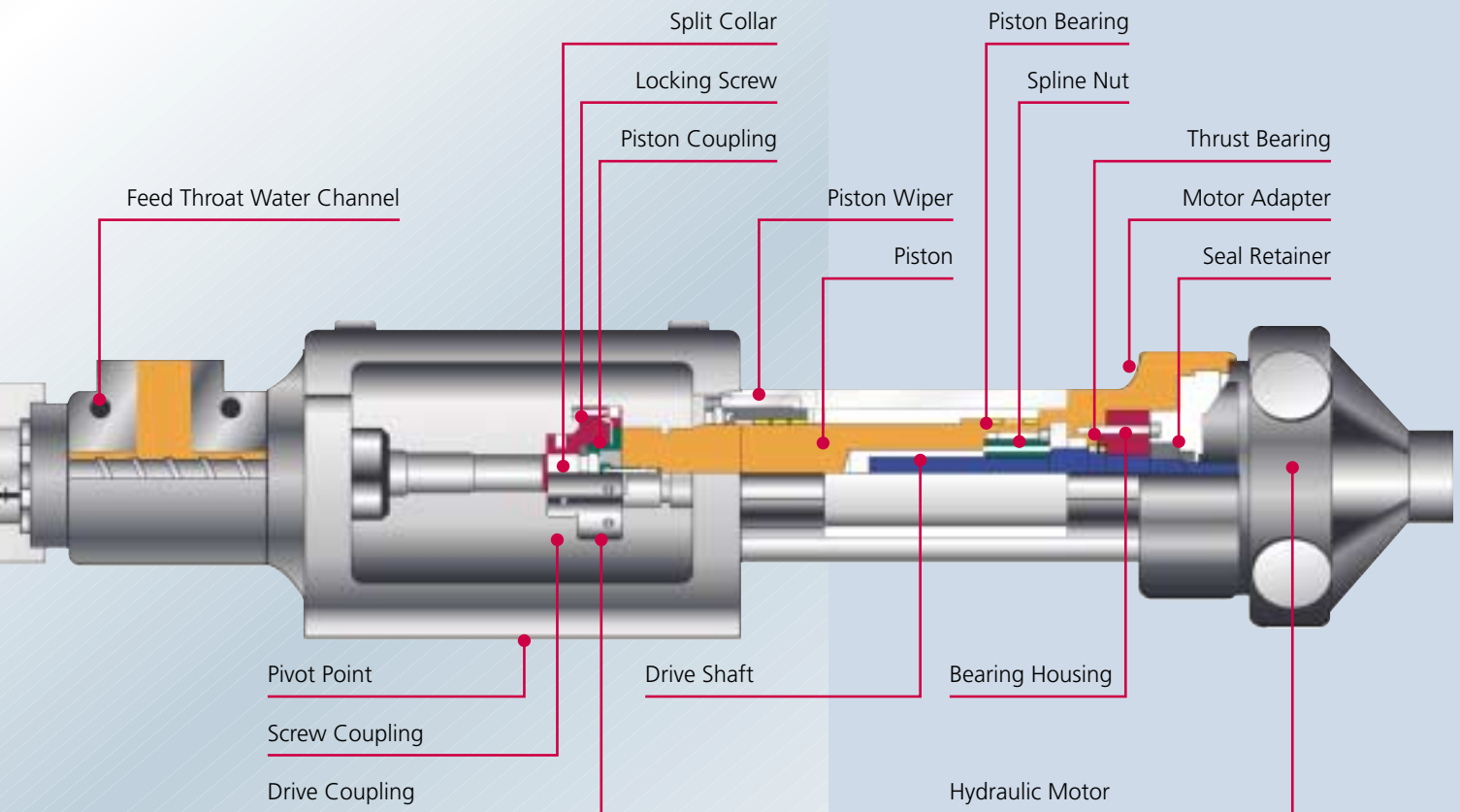

**Other standard features of the injection unit include:**

- Cold screw start-up protection
- Water-cooled feed throat with temperature monitor
- High-wattage mica heater bands
- Screw speed tachometer with the ability to read and adjust RPM profiles from the control. Tachometer is integrated for accuracy, even at low RPMs
- Settable screw rotate delay
- Intrusion molding capability for additional shot size by rotating the screw before injection
- Screw pullback (decompression) before and/or after screw rotate

Another benefit? The twin-cylinder unit includes a power swivel for effortless screw and barrel change. Just three steps are required – first, remove bolts and a pin; second, push a button; and third, watch it move. Precision position sensing of the injection unit is accomplished via linear potentiometer. The Pathfinder control helps you establish initial injection parameters effortlessly through the Scout™ guided setup program.

The Optimizer™ feature makes sure your injection profiles are followed precisely throughout your molding project. State Temperature Control of the nozzle and 4 barrel zones is state-of-the-art and patented. This technology directs barrel temperatures to quickly reach temperature setpoints with reduced overshooting to gain energy savings and protect temperature sensitive materials. State Temperature Control predicts the effects of thermal disturbances such as shear heat or adjacent barrel zone activity and responds quickly to accurately maintain temperatures.

Material degradation is reduced, shot consistency is enhanced and part quality is improved. Barrel high/low temperature alarms and thermocouple break alarms are provided via the control system. Standard sprue break allows you to select one of two sequences or OFF. Sequence selections are available for molds that require hot runner decompression (nozzle breakaway), or stack molds.

# OPTIONS

## Completely Modular

**The Caliber Series is modularly designed so it will easily accept a wide range of options. For an automotive molder, we took this in-stock 1100 Caliber and added bolted-on water manifolds, core pull option and additional electrical power package and still delivered the machine in three week's time.**

The Caliber design is very unique in that it is adaptable to a field-build process referred to as the "BLT" process (Build Large Tonnage). Because of its unique, simple design (Calibers 2200 tons and above) can be broken into smaller subassemblies that can be pretested without full machine assembly at Van Dorn Demag.

As a result, we seek to lead the way in customer service. Van Dorn Demag customers will be able to deliver parts to their customers faster as a direct result of a decrease in lead-time.

### GENERAL FEATURES

The Caliber Series also includes:

- Windows on the movable gates for visibility
- Hydraulics fitted for additional external filtration system
- Gate rail on the non-operator side eliminated for mold and automation access
- Sprue break
- Power-operated front gate
- Hydraulic power unit guards for quiet operation
- Platens predrilled for simple robot mounting
- Robot interface
- Vibration mounting pads
- UL and CUL-approved control cabinet
- ANSI/SPI B151.1-1997 compliant
- Standard machine is wired for 460/3/60 – alternatives are available





**PATHFINDER (P6000)**

The Caliber comes with controls that are easily understood, yet sophisticated enough to take the machine to the next level of performance.

**OPTIONS**

The Caliber Series is available with a broad range of options:

- Core and ejector motion key switch
- Core pull: choice of set and pull sequences
- Feed-throat temperature control
- High-speed and accumulator models
- High-pressure injection
- Electric screw drive
- Co-injection
- Special application screws and barrels
- Configurable Inputs and Outputs
- Variable-speed electric pump drive
- Air eject
- Swing-away arm and hopper
- High base option (1100 to 2200)



Additional pre-engineered options are available. Consult your Van Dorn Demag representative for information on these options and special application requirements.

# MOLDER ACTION NETWORK

Our commitment to 100 percent customer satisfaction is part of the Van Dorn experience. That is why we created the Molder Action Network – total support with one call. Contact us at 866-491-1045 or visit [www.molderactionnetwork.com](http://www.molderactionnetwork.com).



## REPLACEMENT PARTS

Van Dorn maintains an extensive, computerized inventory of replacement parts to assure customers of quick delivery.



## TECHNICAL SERVICE

The Molder Action Network's Technical Service Department is standing by with a wide range of services – installation and start-up, troubleshooting, field service and preventive maintenance.



## TRAINING

We offer classes at three different customer training centers located in Strongsville, Ohio; Greenville, South Carolina; and Roselle, Illinois. Training, tailored to meet your needs, can also be arranged at your facility.



## PROCESS SOLUTIONS CENTER

This center, available to customers before and after a sale, is a state-of-the-art lab facility for mold trials, machine run-offs prior to delivery or troubleshooting processes in the field.

## ENERGY SAVINGS

Sky-rocketing energy costs have changed the economics of the injection molding business. The Molder Action Network can help you cut your power bills down to size.

## ONLINE STORE

Order parts from our new online store where convenience and ease are our main priority. We can accept payment via credit cards or purchase orders.

**Van Dorn Demag Corporation**  
11792 Alameda Drive  
Strongsville, Ohio 44149 USA  
tel: 440/876.8960, fax: 440/876.4383  
web: [www.vandorndemag.com](http://www.vandorndemag.com)  
e-mail: [susan.mann@dpg.com](mailto:susan.mann@dpg.com)

Since continuous improvement is Van Dorn Demag's policy, we reserve the right to change information without prior notice or obligation.